

Standard Gas Pipe Packaging

Coil Packaging

1/2" CTS Sizes

1. Before a completed coil is removed from the winder, the coil is banded together in three locations 120° apart. Caps are placed on the coil ends.
2. The completed coil is then removed from the winder and is placed on a pallet covered with cardboard. The first coil is banded to each of the four sides of the pallet through holes cut in the cardboard.
3. 500' coils are stacked 18 high per pallet. All coils are banded at four points alternating 45° for each set of bands. Coils 1-2 are banded to the pallet. Coils 2-4 are banded together (overlap on coil 2), then every three coils are banded together moving up (coils 4-6, then 6-8, etc.) These coil-to-coil bands are placed 90° apart for improved stability. Four more bands are secured around the entire stack through the center. Corner guards are used where the bands exert pressure on the pipe at the top of the stack.
4. 1,000' coils are stacked 11 high per pallet. Coils 1-4 are banded together, then 4-9, then 7-11. Two more bands are secured around the entire stack through the center. Corner guards are used where the bands exert pressure on the pipe at the top of the stack.
5. The palletized stack is then shrink-wrapped twice and is ready to be loaded on a truck.

3/4" IPS Sizes

1. If incremental banding is desired, each coil of pipe is banded at intervals as it is coiled during production. The first band is placed after two layers have been coiled and then a band is added every two subsequent layers. The final band is positioned to keep the loose pipe ends secure.
2. After the coil is complete, three more bands are wrapped around the entire coil 120° apart. Caps are placed on the coil ends.
3. The coil is removed from the winder and is placed on a pallet covered with cardboard. The first coil is banded to each of the four sides of the pallet.
4. Coils are stacked 7 high. Coils 1-4 are banded together and stacks 4-7 are banded together. Two more bands are secured around the entire stack through the center.
5. The palletized stack is then shrink-wrapped twice and is ready to be loaded on a truck.

1" CTS Sizes

1. Before a completed coil is removed from the winder, the coil is banded in three locations 120° apart. One of the three locations is 6" from the loose end at the outer diameter of the coil. Caps are placed on the coil ends.
2. The coil is then removed from the winder and is placed on a pallet covered with cardboard. The first coil is banded to each of the four sides of the pallet.
3. Coils are stacked 6 high. Coils 1-3 are banded together and stacks 3-6 are banded together. Two more bands are secured around the entire stack through the center.
4. The palletized stack is then shrink-wrapped twice and is ready to be loaded on a truck.

2" IPS Sizes

1. Before a completed coil is removed from the winder, the coil is banded in three locations 120° apart. One of the three locations is 6" from the loose end at the outer diameter of the coil. Caps are placed on the coil ends.
2. The coil is then removed from the winder and is placed on a pallet covered with cardboard. The first coil is banded to the pallet.
3. 500' coils are stacked 7 high. The first coil is banded to the pallet in two opposite corners. Coils are then banded to each successive coil as they are stacked (coils 1-2, then 2-3, then 3-4, then 4-5, then 6-7). Two more bands are secured around the entire stack through the center.
4. 1,500' coils are stacked two high. The first coil is banded to each of the four sides of the pallet. The second is banded to the first coil. Two more bands are secured around the entire stack through the center.
5. The palletized stack is then shrink-wrapped twice and is ready to be loaded on a truck.

4" IPS Sizes

1. Before a completed coil is removed from the winder, the coil is banded in three locations 120° apart at each layer of the coil. Bands are used as necessary at the end of the coil to contain the tail of the pipe. Caps are placed on the coil ends.
2. The coil is then removed from the winder and is placed on a 96" pallet. The first coil is banded to the pallet through holes cut in the cardboard.
3. 500' coils are stacked 2 high. The first coil is banded to the pallet in two opposite corners. The second pallet is banded in four opposite corners, providing more security for both coils.
4. The palletized stack is then shrink-wrapped and is ready to be loaded on a truck.
5. 1,000'+ coils are packaged individually using a special cradle pallet. The cradles hold the coils vertically, which allows them to be handled easier in the field.

6" IPS Sizes

1. Before a completed coil is removed from the winder, the coil is banded in six locations 60° apart at each layer of the coil. Bands are used as necessary at the end of the coil to contain the tail of the pipe. Caps are placed on the coil ends.
2. 500' coils are placed upright on a single cradle-style pallet. Coil is banded in four locations to the pallet.

Stick Packaging

2" IPS Stick Packaging Configuration 93 Sticks/Bundle

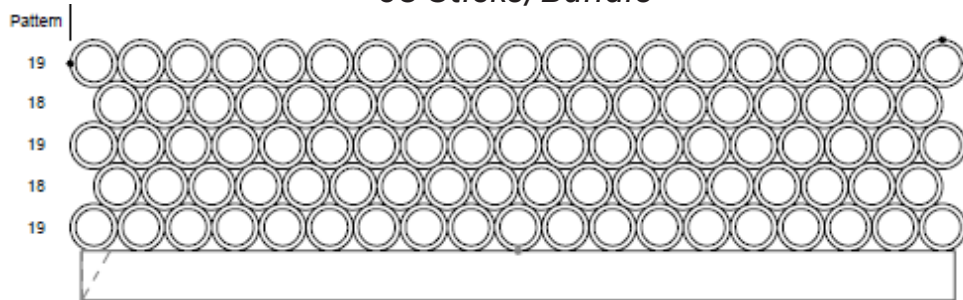

Size	SDR		Stick Length (ft)	Bundle Weight (lbs)	Stick Weight (lbs)
2"	11	MDPE	20	1,168	13
			40	2,336	25
		HDPE	20	1,181	13
			40	2,361	25

Measures are approximate and may vary.

3" IPS Stick Packaging Configuration

50 Sticks/Bundle

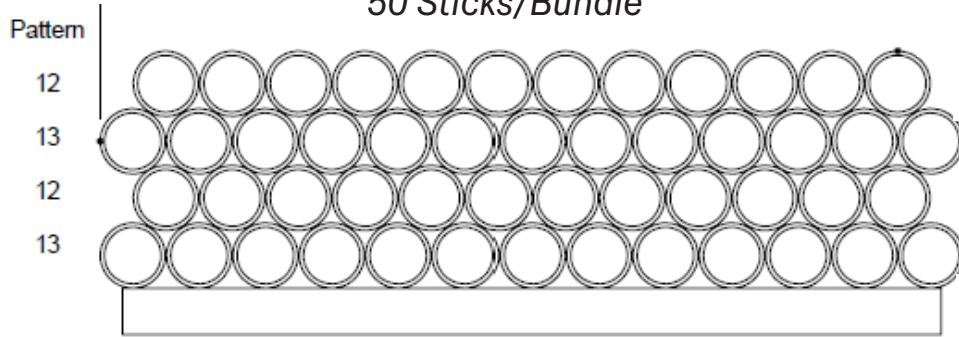

Size	SDR	Material	Stick Length (ft)	Bundle Weight (lbs)	Stick Weight (lbs)
3"	11	MDPE	20	1,363	27
			40	2,726	55
		HDPE	20	1,378	28
			40	2,755	55
	11.5	MDPE	20	1,310	26
			40	2,620	52
		HDPE	20	1,324	26
			40	2,648	53

Measures are approximate and may vary.

4" IPS Stick Packaging Configuration

30 Sticks/Bundle

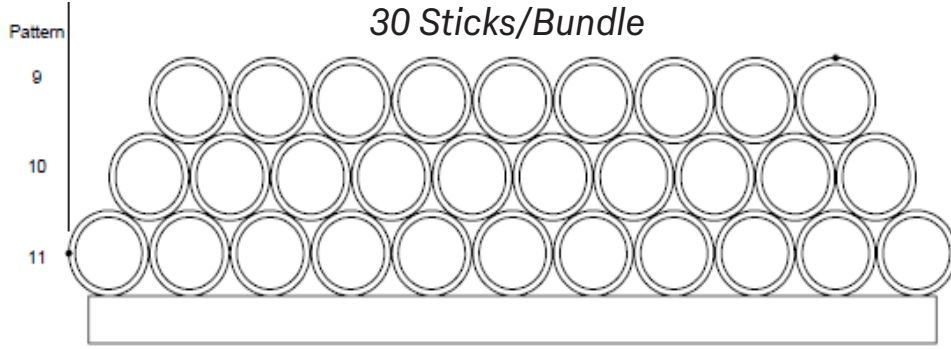

Size	SDR	Material	Stick Length (ft)	Bundle Weight (lbs)	Stick Weight (lbs)
4"	11	MDPE	20	1,352	45
			40	2,704	90
		HDPE	20	1,366	46
			40	2,732	91
	11.5	MDPE	20	1,298	43
			40	2,597	87
		HDPE	20	1,312	44
			40	2,624	87
	13.5	MDPE	20	1,123	37
			40	2,245	75
		HDPE	20	1,135	38
			40	2,269	76

Measures are approximate and may vary.

6" IPS Stick Packaging Configuration

13 Sticks/Bundle

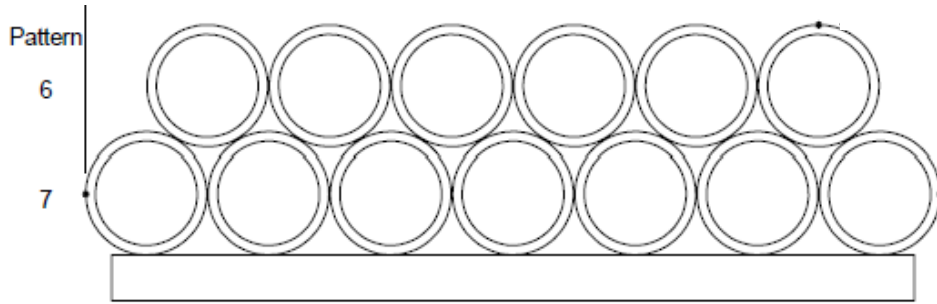

Size	SDR	Material	Stick Length (ft)	Bundle Weight (lbs)	Stick Weight (lbs)
6"	11	MDPE	20	1,269	98
			40	2,539	195
		HDPE	20	1,283	99
			40	2,566	197
	11.5	MDPE	20	1,220	94
			40	2,440	188
		HDPE	20	1,233	95
			40	2,466	190
	13.5	MDPE	20	1,056	81
			40	1,056	162
		HDPE	20	2,111	82
			40	2,134	164

Measures are approximate and may vary.